



Air-Cooled Screw Chillers RTAF-G 320 – 1720 kW

The best bundled in one.
Our best.

SINTECIS™
PRIME



The Future of F-Gases

The fluorinated refrigerants phase-down, as defined in the new EU F-Gas Regulation, is a step-by-step approach where the quantities of HFCs expressed in CO₂ equivalent that are placed on the market are gradually reduced. As a result of the phase-down, HFC consumption will be reduced by 79% by 2030.

This is an unprecedented reduction and means that industry and users need to make, over time, the transition to refrigerants with a lower global warming potential. In 2018, the first major step in the phase-down resulted in a substantial refrigerant cost correction.

Trane, recognized as a leading innovator in the HVAC industry, introduces this new GWP<1 R1234ze refrigerant in Sintesis and other products to be front running in the marketplace and to support your strong sustainability objectives.

Ingersoll Rand and Trane - providers of sustainable solutions.

HFC consumption

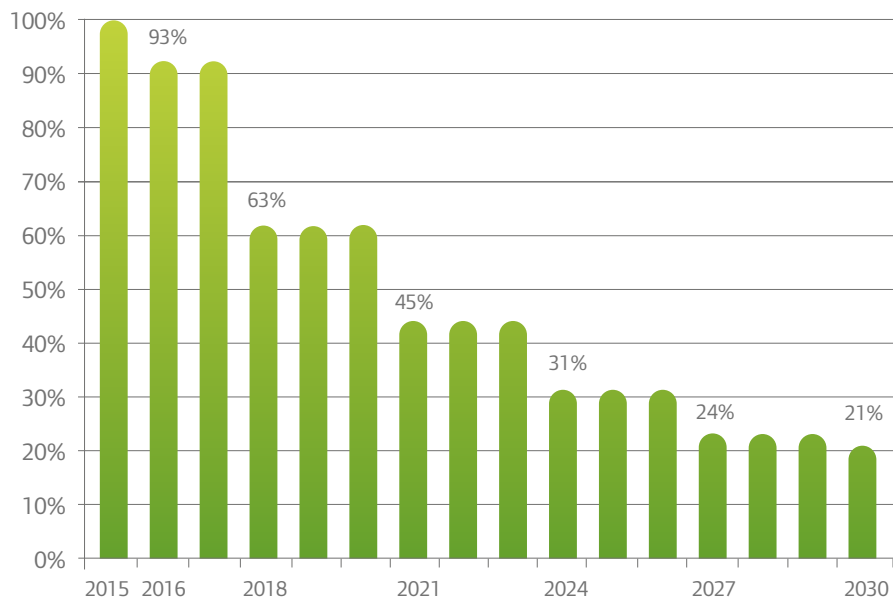

Baseline value (100%) is the annual average of total quantity of CO₂ equivalents placed on the EU market from 2009 to 2012.

An environmentally sustainable solution

EcoWise™

Sintesis™ chillers are part of the Ingersoll Rand EcoWise™ portfolio of products that are designed to lower their environmental impact with next-generation, low global warming potential (GWP) refrigerants and high-efficiency operation.

- **High efficiency operation** – To deliver lower operating costs, Sintesis chillers are optimized for both full- and part-load performance.
- **Lower refrigerant charge** – The CHIL evaporator and microchannel condenser reduce the amount of refrigerant required by up to 40 percent compared to earlier designs, making it even easier to earn points under the LEED® Energy and Atmosphere (EA) Credit for Enhanced Refrigerant Management.
- **Low GWP refrigerant option** – Sintesis chillers are designed to operate with R-134a, DuPont™ Opteon® XP10 (R-513A) or Solstice® ze (R-1234ze).
- **Reduced risk of refrigerant leaks** – The microchannel design used in Sintesis chillers eliminates brazed U-bend connections and their potential for refrigerant leaks, helping maintain peak chiller efficiency and reliability.

What is GWP?

GWP is the global warming impact relative to the impact of the same quantity of carbon dioxide over a 100 year period.

Example:

R1234ze: GWP = <1

CO₂: GWP = 1

R513A: GWP = 631

R134a: GWP = 1430

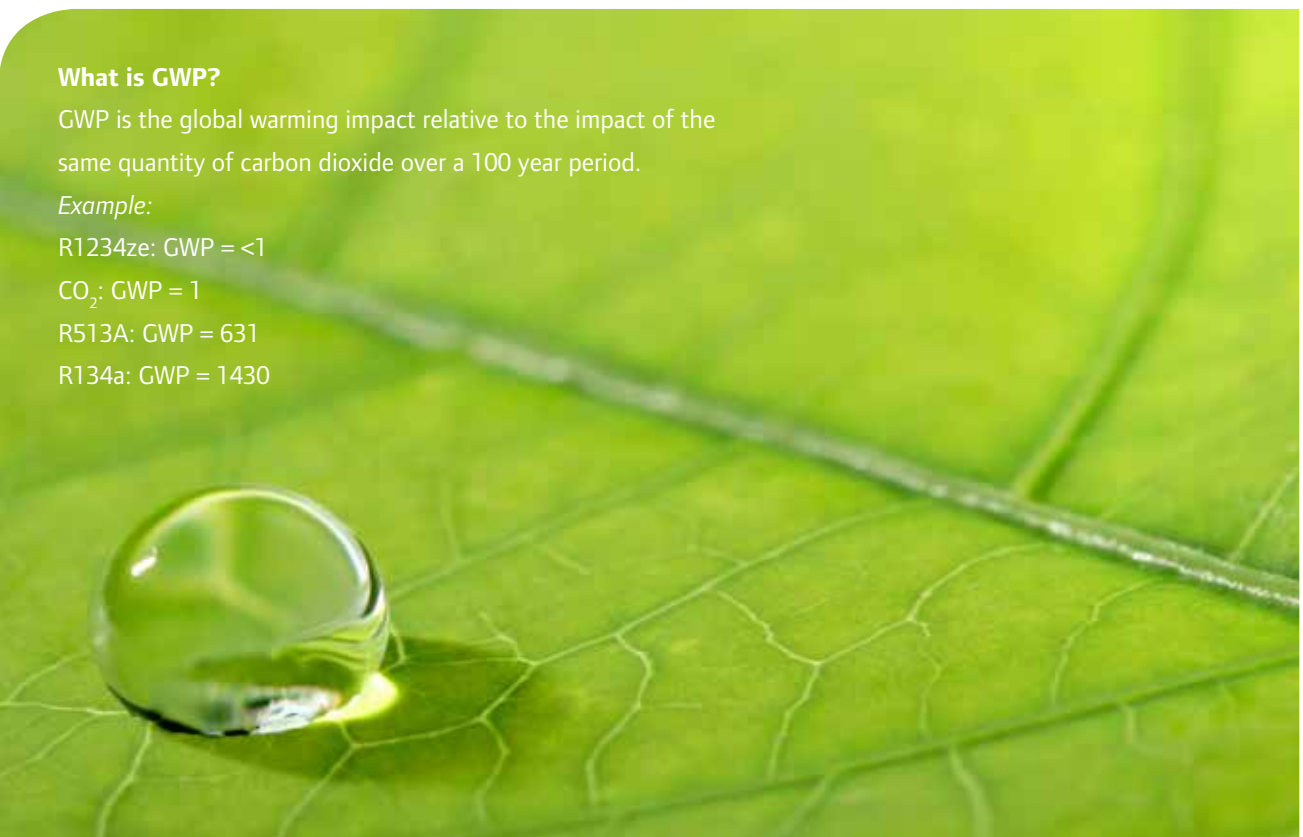

The total package

Quality, performance and reliability

The Trane advantage

Trane is recognized as a world leader with over 100 years of experience in creating and sustaining safe, comfortable and energy efficient environments while improving the performance of buildings and processes around the world.

Trane solutions optimize indoor environments with a broad portfolio of energy efficient heating, ventilating and air conditioning systems, building services, parts support and advanced controls.

To ensure your equipment continues to work at its optimum, throughout the life of the building, Trane provides a full range of service solutions, combined with in-house expertise and an extensive support network.

The Trane offering is...

Smart



Reliable



Energy Efficient



Quiet





Smart Com interface

The Smart Com interface provides complete connectivity with LonTalk®, BACnet®, Modbus and Trane BMS for remote monitoring.

Total control over your system to optimize performance and reliability.

- 7" touch screen
- Intuitive menus
- Easy to use
- Full monitoring of data, settings and alarms
- Full connectivity for remote monitoring
- Trane will design the ideal control solution for your building

Smart flow control

- Trane Adaptive Frequency™ Drive on water pumps
- Variable primary flow to best adapt to jobsite conditions and energy savings

The best in quality, the best in reliability

At Trane we manufacture what we supply, so we enjoy full control from concept to delivery.

Our test procedures are the most rigorous in the industry, so your system will be totally dependable under the most demanding conditions.

Specialist industrial designers ensure every unit is as good looking as the building it is going into.

Because of the confidence we have in our products, we can offer the Trane Select 10 year warranty.

Total compliance

Trane ensures that all our products meet or exceed all requirements for efficiency, noise, refrigerants and safety. This means you can have total peace of mind.

The Trane model RTAF-G operates with R1234ze refrigerant which has a GWP value of less than one to exceed current F-Gas legislation requirements and help customers reduce their carbon dioxide (CO₂) emissions. The complete range of sizes also achieves excellent part load efficiencies to comply with current Ecodesign requirements for Comfort chillers.

A specific RTAF-G unit design specially dedicated to process applications with brine (ethylene glycol, propylene glycol, etc) applications is capable of supplying negative leaving brine temperature on process applications and surpasses the latest Medium Temperature Ecodesign Requirements.

A wide capacity range up to 1.7 MW

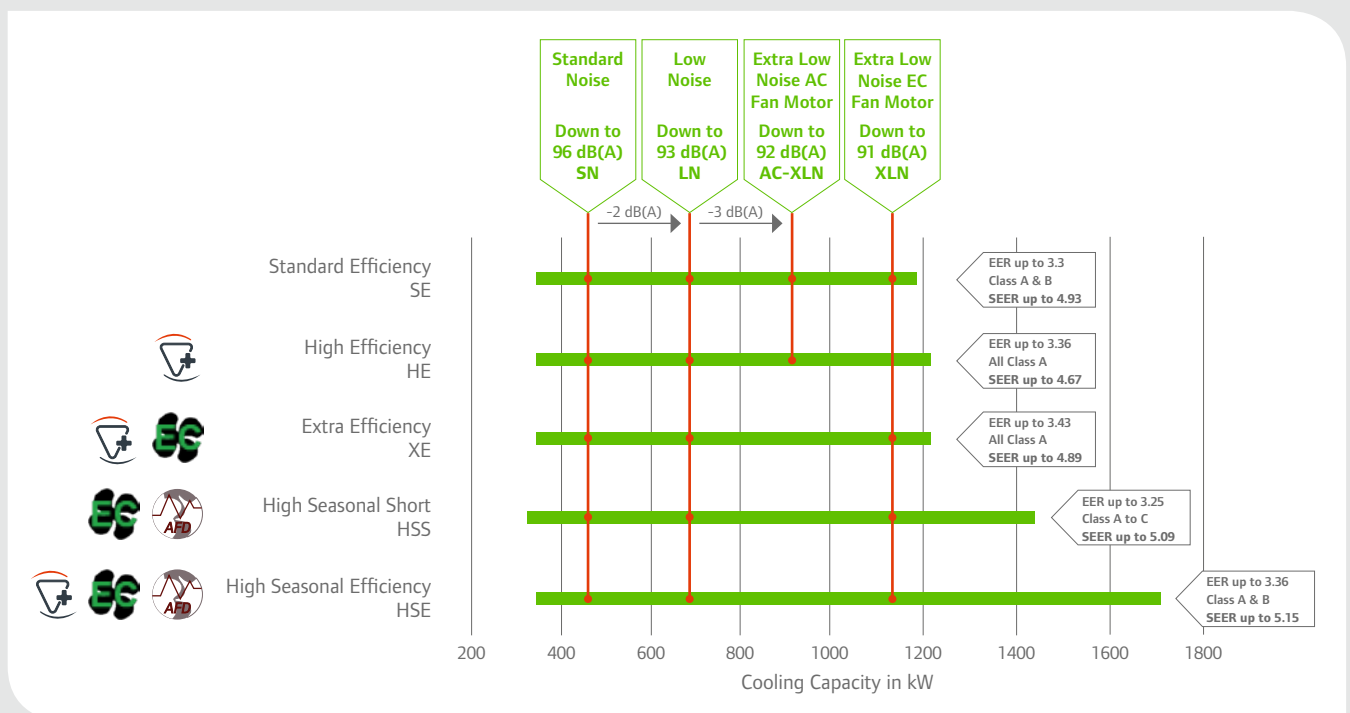

Operating limits

			RTAF G
Condenser Ambient Temperature			
Standard (min/max)	(°C)		-10 / +46
with Low Ambient option (min/max)	(°C)		-20 / +46
with High Ambient option (min/max)	(°C)		-10 / +55
Evaporator Leaving Water Temperature			
Standard (min/max)	(°C)		-12 / +27
RTAF G Process range	(°C)		-12 / +4.4
Power supply	(V/Ph/Hz)		400/3/50
Refrigerant			R1234ze

Sintesis Prime RTAF-G is suited to critical environments like



Office buildings



Healthcare



Data Centers



Automotive industry

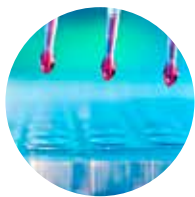

Pharmaceutical industry



Plastic industry



Hospitality industry



District Cooling

Trane Proprietary Technology*

Provides the innovative solution your building needs

2 *Redesigned fan diffusers

- Remodelled to optimize airflow
- Fans consume less power
- Operating noise reduced

3 * Micro-channel condenser coils

- Leading edge coil design for increased corrosion resistance
- Longer life expectancy
- Increased efficiency with less refrigerant
- Reduced carbon footprint
- 10% overall unit weight reduction

4 * Trane smart control and interface combined

- Leading TD7 touch screen with 7" color display
- Clear display of critical information
- Monitor settings, data trending, reports and alarms
- Simple, intuitive navigation
- Effective operation, monitoring and management
- Durable construction for both indoor and outdoor use

1 Electronically Commutated (EC) fans

- Improved capacity modulation
- Reduced power consumption
- Reduced energy costs



*** Compact - High performance - Integrated design**
- Low charge (CHIL) flooded evaporator

- Reduced refrigerant volume
- Increased efficiency
- Reduced carbon footprint



*** Tracer™ UC800 controller**

- New generation of Trane control platform for chillers
- Advanced algorithms for the most challenging conditions
- Perfect balance of performance and economy



*** Connectivity**

- Full interoperability via SmartCom interface Lontalk®, BACnet® and Modbus
- Full remote control capability via our Trane BMS

Adaptive Frequency™ Drive on HSE and HSS versions

- Improved efficiency under part load conditions
- Improved capacity modulation
- Current surge reduced by a factor of 5



5 * Trane Compressor

- Direct drive, two screws helical rotary design
- Infinite capacity modulation via the slide valve
- Trane legendary reliability

Three different refrigerant alternatives

- R134a
- R513A
- R1234ze





An affordable choice of sound versions

- Choose from five levels of sound attenuation depending on the sensitivity of the application.
- Achieved without any loss of operating efficiency and even improving performances with the Extra Low Noise-EC version

Standard Noise: SN - average sound power Lw 98 dB(A)

Low Noise: LN - average sound power Lw 96 dB(A)

- Compressor enclosure
- Additional insulation on the refrigerant circuit

Low Noise Night Noise Set Back: LN-NNSB - average sound power Lw 96 dB(A)

- Compressor enclosure
- Additional insulation on the refrigerant circuit
- Night noise set back option

Extra Low Noise-AC: XLN-AC - average sound power Lw 93 dB(A)

- Compressor enclosure
- Refrigerant line insulation

Extra Low Noise-EC: XLN-EC - average sound power Lw 93 dB(A)* 

- Compressor enclosure
- Refrigerant line insulation
- EC fans with top diffusers



* The lowest noise rating on the market.

Sound levels

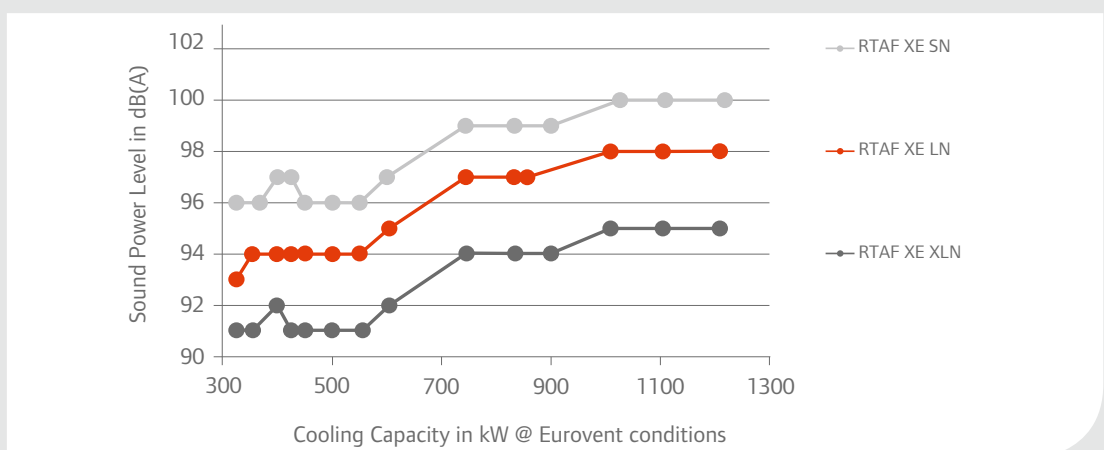

XLN-EC

The quietest in the industry!

The lowest sound levels...

Extra Low Noise EC (XLN-EC): Lw from 91 to 101dB(A) across the range thanks to:

- Compressor enclosure
- Refrigerant line insulation
- EC fans with top diffusers



...at the efficiency that you need

The **XLN-EC** (Extra Low Noise EC)* version improves unit efficiency even further and is available in five efficiency levels

- **High Efficiency (HE)**: Class A with SEER up to 4.67
- **Standard Efficiency (SE)**: Class B/A with SEER up to 4.93
- **Extra Efficiency (XE)**: Class A with SEER up to 4.89
- **High Seasonal Short (HSS)** with Trane Adaptive Frequency™ Drive and a reduced footprint
- **High Seasonal Efficiency (HSE)**: using Trane Adaptive Frequency™ Drive technology on the compressors allowing SEER up to 5.15



Heat Recovery

Heat recovery is reusing the energy which is produced as a natural by-product of the cooling cycle. Trane Sintesis chillers with Partial or Total Heat Recovery option combine the energy savings from heat recovery operation with the cost savings from installation and maintenance. Units with the Heat Recovery option operate as a standard chiller as long as heat is not required or can simultaneously produce chilled and hot water for use in applications like:

- Heating or preheating of boiler systems or domestic cater
- Air conditioning
- Ventilation air pre-heating
- Industrial processes.

Trane Sintesis model RTAF offers a heating capacity

- up to 25% of the cooling capacity with Partial Heat Recovery (PHR) option.
- up to 130% of the cooling capacity with Total Heat Recovery (THR) option.

Free-Cooling

Take the advantage of low ambient conditions to help cool water in your HVAC system.

- A small footprint compared to a system where a dry cooler and a chiller are used
- One single equipment control
- A wide range of capacities

Choose from four free-cooling alternatives.

- Total Direct Free-cooling
- Partial Direct Free-cooling
- Total Glycol-Free Free-cooling
- Partial Glycol-Free Free-cooling





General specifications

XE

RTAF XE - Extra Efficiency - Extra Low Noise - EC



Eurovent performances (1)		090	100	110	120	130	145	155
Net cooling capacity (1) (2)	(kW)	328	359	394	426	459	508	552
Net EER (1) (2)		3.35	3.33	3.30	3.34	3.38	3.43	3.37
Eurovent Energy class - Cooling		A	A	A	A	A	A	A
Net ESEER (2)		3.89	3.93	3.93	4.02	4.12	4.22	4.15
SEER (3)		4.18	4.22	4.26	4.34	4.45	4.62	4.51
Space cooling efficiency $\eta_{s.c}$ (3)	(%)	164	166	167	171	175	182	177
Sound power level	(dB(A))	91	91	92	91	91	91	91

Compressor

Circuit 1		1	1	1	1	1	1	1
Circuit 2		1	1	1	1	1	1	1

Refrigerant

Type		R1234ze						
Charge Circuit 1	(kg)	44	43	43	44	45	58	58
Charge Circuit 2	(kg)	42	41	41	45	43	48	48

Dimensions & Weight

Length	(mm)	5645	5645	5645	5645	5645	6770	6770
Width	(mm)	2200	2200	2200	2200	2200	2200	2200
Height	(mm)	2672	2672	2672	2672	2672	2672	2672
Operating weight	(kg)	3710	3745	3745	4345	4520	4665	4690

Eurovent performances (1)		185	210	230	265	285	305	340
Net cooling capacity (1) (2)	(kW)	614	740	835	910	1025	1115	1223
Net EER (1) (2)		3.37	3.30	3.34	3.28	3.27	3.22	3.30
Eurovent Energy class - Cooling		A	A	A	A	A	A	A
Net ESEER (2)		4.01	4.37	4.34	4.33	4.47	4.59	4.25
SEER (3)		4.40	4.73	4.80	4.76	4.89	4.89	4.85
Space cooling efficiency $\eta_{s.c}$ (3)	(%)	173	186	189	187	193	193	191
Sound power level	(dB(A))	92	94	94	94	95	95	95

Compressor

Circuit 1		1	2	2	2	2	2	2
Circuit 2		1	1	1	1	2	2	2

Refrigerant

Type		R1234ze						
Charge Circuit 1	(kg)	63	98	104	104	100	102	102
Charge Circuit 2	(kg)	49	40	49	49	92	96	102

Dimensions & Weight

Length	(mm)	7895	9390	10135	10135	12385	12385	13510
Width	(mm)	2200	2200	2200	2200	2200	2200	2200
Height	(mm)	2672	2672	2672	2672	2672	2672	2672
Operating weight	(kg)	4770	7035	7515	7535	9140	9365	9675

(1) Evaporator 12/7°C and 0.0 m²K/kW, and condenser at 30/35°C and 0.0 m²K/kW

(2) Net performances calculated as per EN 14511-2013.

(3) $\eta_{s.c}$ / SEER as defined in Directive 2009/125/EC of the European Parliament and of the Council with regard to Ecodesign requirements for Comfort Chillers with 2000 kW maximum capacity - COMMISSION REGULATION (EU) N° 2016/2281 of 20 December 2016



RTAF XE - Extra Efficiency - Standard and Low Noise

Eurovent performances (1)		090	100	110	120	130	145	155
Net cooling capacity (1) (2)	(kW)	328	360	395	427	459	509	552
Net EER (1) (2)		3.32	3.31	3.27	3.31	3.35	3.39	3.34
Eurovent Energy class - Cooling		A	A	A	A	A	A	A
Net ESEER (2)		3.85	3.89	3.90	3.98	4.07	4.18	4.10
SEER (3)		4.14	4.19	4.22	4.30	4.39	4.58	4.46
Space cooling efficiency $\eta_{s,c}$ (3)	(%)	162	165	166	169	173	180	175
Sound power level (standard noise)	(dB(A))	96	96	97	97	96	96	96
Sound power level (low noise)	(dB(A))	93	94	94	94	94	94	94

Compressor								
Circuit 1		1	1	1	1	1	1	1
Circuit 2		1	1	1	1	1	1	1

Refrigerant								
Type		R1234ze						
Charge Circuit 1	(kg)	44	43	43	44	45	58	58
Charge Circuit 2	(kg)	42	41	41	45	43	48	48

Dimensions & Weight								
Length	(mm)	5645	5645	5645	5645	5645	6770	6770
Width	(mm)	2200	2200	2200	2200	2200	2200	2200
Height	(mm)	2526	2526	2526	2526	2526	2526	2526
Operating weight (standard noise)	(kg)	3610	3645	3645	4245	4420	4545	4570

Eurovent performances (1)		185	210	230	265	285	305	340
Net cooling capacity (1) (2)	(kW)	614	741	836	911	1027	1118	1225
Net EER (1) (2)		3.32	3.23	3.27	3.22	3.20	3.17	3.24
Eurovent Energy class - Cooling		A	A	A	A	A	A	A
Net ESEER (2)		3.93	4.33	4.31	4.28	4.42	4.53	4.20
SEER (3)		4.32	4.68	4.76	4.66	4.84	4.84	4.71
Space cooling efficiency $\eta_{s,c}$ (3)	(%)	170	184	187	183	191	191	186
Sound power level (standard noise)	(dB(A))	97	99	99	99	100	100	100
Sound power level (low noise)	(dB(A))	95	97	97	97	98	98	98

Compressor								
Circuit 1		1	2	2	2	2	2	2
Circuit 2		1	1	1	1	2	2	2

Refrigerant								
Type		R1234ze						
Charge Circuit 1	(kg)	63	98	104	104	100	102	102
Charge Circuit 2	(kg)	49	40	49	49	92	96	102

Dimensions & Weight								
Length	(mm)	7895	9390	10135	10135	12385	12385	13510
Width	(mm)	2200	2200	2200	2200	2200	2200	2200
Height	(mm)	2526	2526	2526	2526	2526	2526	2526
Operating weight (standard noise)	(kg)	4650	6855	7315	7335	8900	9125	9435

(1) Evaporator 12/7°C and 0.0 m²K/kW, and condenser at 30/35°C and 0.0 m²K/kW

(2) Net performances calculated as per EN 14511-2013.

(3) $\eta_{s,c}$ / SEER as defined in Directive 2009/125/EC of the European Parliament and of the Council with regard to Ecodesign requirements for Comfort Chillers with 2000 kW maximum capacity - COMMISSION REGULATION (EU) N° 2016/2281 of 20 December 2016

General specifications

HE



RTAF HE - High Efficiency - Extra Low noise - AC

Eurovent performances (1)		100	110	120	130	145	155
Net cooling capacity (1) (2)	(kW)	364	396	428	461	511	555
Net EER (1) (2)		3.23	3.23	3.28	3.32	3.36	3.32
Eurovent Energy class - Cooling		A	A	A	A	A	A
Net ESEER (2)		3.59	3.71	3.82	3.95	3.93	4.03
SEER (3)		3.85	4.01	4.14	4.26	4.29	4.32
Space cooling efficiency $\eta_{s.c}$ (3)	(%)	151	157	162	167	169	170
Sound power level	(dB(A))	92	92	92	92	92	92

Compressor

Circuit 1		1	1	1	1	1	1
Circuit 2		1	1	1	1	1	1

Refrigerant

Type		R1234ze					
Charge Circuit 1	(kg)	43	43	44	45	58	58
Charge Circuit 2	(kg)	41	41	45	43	48	48

Dimensions & Weight

Length	(mm)	5645	5645	5645	5645	6770	6770
Width	(mm)	2200	2200	2200	2200	2200	2200
Height	(mm)	2526	2526	2526	2526	2526	2526
Operating weight	(kg)	3745	3745	4345	4520	4665	4690

Eurovent performances (1)		185	210	265	285	305	340
Net cooling capacity (1) (2)	(kW)	613	736	903	1019	1107	1215
Net EER (1) (2)		3.35	3.27	3.25	3.31	3.25	3.26
Eurovent Energy class - Cooling		A	A	A	A	A	A
Net ESEER (2)		3.90	3.96	4.00	4.21	4.25	4.10
SEER (3)		4.30	4.51	4.52	4.63	4.57	4.67
Space cooling efficiency $\eta_{s.c}$ (3)	(%)	169	177	178	182	180	184
Sound power level	(dB(A))	92	94	94	95	95	95

Compressor

Circuit 1		1	2	2	2	2	2
Circuit 2		1	1	1	2	2	2

Refrigerant

Type		R1234ze					
Charge Circuit 1	(kg)	63	98	104	100	102	102
Charge Circuit 2	(kg)	49	40	49	92	96	102

Dimensions & Weight

Length	(mm)	7895	9390	10135	12385	12385	13510
Width	(mm)	2200	2200	2200	2200	2200	2200
Height	(mm)	2526	2526	2526	2526	2526	2526
Operating weight	(kg)	4770	7035	7535	9140	9365	9675

(1) Evaporator 12/7°C and 0.0 m²K/kW, and condenser at 30/35°C and 0.0 m²K/kW

(2) Net performances calculated as per EN 14511-2013.

(3) $\eta_{s.c}$ / SEER as defined in Directive 2009/125/EC of the European Parliament and of the Council with regard to Ecodesign requirements for Comfort Chillers with 2000 kW maximum capacity - COMMISSION REGULATION (EU) N° 2016/2281 of 20 December 2016



RTAF HE - High Efficiency - Standard and Low Noise

Eurovent performances (1)		130	145	155	185	210
Net cooling capacity (1) (2)	(kW)	463	512	557	614	739
Net EER (1) (2)		3.27	3.30	3.27	3.29	3.22
Eurovent Energy class - Cooling		A	A	A	A	A
Net ESEER (2)		3.84	3.85	3.85	3.80	3.95
SEER (3)		4.15	4.21	4.20	4.19	4.38
Space cooling efficiency $\eta_{s,c}$ (3)	(%)	163	165	165	165	172
Sound power level (standard noise)	(dB(A))	97	97	97	97	99
Sound power level (low noise)	(dB(A))	94	95	95	95	96
Compressor						
Circuit 1		1	1	1	1	2
Circuit 2		1	1	1	1	1
Refrigerant						
Type		R1234ze				
Charge Circuit 1	(kg)	45	58	58	63	98
Charge Circuit 2	(kg)	43	48	48	49	40
Dimensions & Weight						
Length	(mm)	5645	6770	6770	7895	9390
Width	(mm)	2200	2200	2200	2200	2200
Height	(mm)	2526	2526	2526	2526	2526
Operating weight (standard noise)	(kg)	4420	4545	4570	4650	6855

Eurovent performances (1)		230	265	285	305	340
Net cooling capacity (1) (2)	(kW)	835	907	1024	1114	1219
Net EER (1) (2)		3.26	3.21	3.26	3.22	3.23
Eurovent Energy class - Cooling		A	A	A	A	A
Net ESEER (2)		3.99	3.89	4.02	4.08	3.99
SEER (3)		4.36	4.41	4.55	4.51	4.55
Space cooling efficiency $\eta_{s,c}$ (3)	(%)	172	174	179	177	179
Sound power level (standard noise)	(dB(A))	98	99	100	100	100
Sound power level (low noise)	(dB(A))	97	97	98	98	98
Compressor						
Circuit 1		2	2	2	2	2
Circuit 2		1	1	2	2	2
Refrigerant						
Type		R1234ze				
Charge Circuit 1	(kg)	104	104	100	102	102
Charge Circuit 2	(kg)	49	49	92	96	102
Dimensions & Weight						
Length	(mm)	10135	10135	12385	12385	13510
Width	(mm)	2200	2200	2200	2200	2200
Height	(mm)	2526	2526	2526	2526	2526
Operating weight (standard noise)	(kg)	7315	7335	8900	9125	9435

(1) Evaporator 12/7°C and 0.0 m³K/kW, and condenser at 30/35°C and 0.0 m³K/kW

(2) Net performances calculated as per EN 14511-2013.

(3) $\eta_{s,c}$ / SEER as defined in Directive 2009/125/EC of the European Parliament and of the Council with regard to Ecodesign requirements for Comfort Chillers with 2000 kW maximum capacity - COMMISSION REGULATION (EU) N° 2016/2281 of 20 December 2016

General specifications

SE



RTAF SE - Standard Efficiency - Extra Low Noise - EC

Eurovent performances (1)		090	100	110	120	130	145	155
Net cooling capacity (1) (2)	(kW)	329	360	391	423	455	507	550
Net EER (1) (2)		3.18	3.17	3.15	3.18	3.18	3.29	3.23
Eurovent Energy class - Cooling		A	A	A	A	A	A	A
Net ESEER (2)		3.81	3.83	3.83	3.90	3.94	4.05	3.96
SEER (3)		4.09	4.14	4.14	4.23	4.24	4.45	4.29
Space cooling efficiency $\eta_{s,c}$ (3)	(%)	161	162	162	166	167	175	169
Sound power level	(dB(A))	92	92	92	92	92	92	92
Compressor								
Circuit 1		1	1	1	1	1	1	1
Circuit 2		1	1	1	1	1	1	1
Refrigerant								
Type		R1234ze						
Charge Circuit 1	(kg)	41	40	40	41	42	55	55
Charge Circuit 2	(kg)	39	38	38	42	40	45	45
Dimensions & Weight								
Length	(mm)	4520	4520	4520	4520	4520	5645	5645
Width	(mm)	2200	2200	2200	2200	2200	2200	2200
Height	(mm)	2672	2672	2672	2672	2672	2672	2672
Operating weight	(kg)	3410	3445	3445	4045	4220	4365	3310

Eurovent performances (1)		185	210	230	265	285	305	340
Net cooling capacity (1) (2)	(kW)	608	734	816	898	1007	1093	1201
Net EER (1) (2)		3.30	3.24	3.12	3.20	3.19	3.11	3.16
Eurovent Energy class - Cooling		A	A	A	A	A	A	A
Net ESEER (2)		3.90	4.32	4.13	4.15	4.38	4.49	4.18
SEER (3)		4.39	4.47	4.50	4.72	4.54	4.93	4.72
Space cooling efficiency $\eta_{s,c}$ (3)	(%)	173	176	177	186	179	194	186
Sound power level	(dB(A))	92	94	94	94	95	95	95
Compressor								
Circuit 1		1	2	2	2	2	2	2
Circuit 2		1	1	1	1	2	2	2
Refrigerant								
Type		R1234ze						
Charge Circuit 1	(kg)	60	90	93	93	90	94	94
Charge Circuit 2	(kg)	46	40	44	49	88	91	96
Dimensions & Weight								
Length	(mm)	6770	8265	8265	9390	10135	10135	11260
Width	(mm)	2200	2200	2200	2200	2200	2200	2200
Height	(mm)	2672	2672	2672	2672	2672	2672	2672
Operating weight	(kg)	4470	6715	6875	7230	8605	8765	9060

(1) Evaporator 12/7°C and 0.0 m³K/kW, and condenser at 30/35°C and 0.0 m³K/kW

(2) Net performances calculated as per EN 14511-2013.

(3) $\eta_{s,c}$ / SEER as defined in Directive 2009/125/EC of the European Parliament and of the Council with regard to Ecodesign requirements for Comfort Chillers with 2000 kW maximum capacity - COMMISSION REGULATION (EU) N° 2016/2281 of 20 December 2016



RTAF SE - Standard Efficiency - Extra Low Noise - AC

Eurovent performances (1)		090	100	110	130	145	155	185
Net cooling capacity (1) (2)	(kW)	328	359	389	451	503	545	606
Net EER (1) (2)		3.16	3.14	3.12	3.13	3.25	3.18	3.27
Eurovent Energy class - Cooling		A	A	A	A	A	A	A
Net ESEER (2)		3.58	3.62	3.60	3.85	3.92	3.83	3.89
SEER (3)		3.83	3.90	3.86	4.16	4.22	4.15	4.30
Space cooling efficiency $\eta_{s,c}$ (3)	(%)	150	153	151	163	166	163	169
Sound power level	(dB(A))	92	92	92	92	92	92	92

Compressor

Circuit 1		1	1	1	1	1	1	1
Circuit 2		1	1	1	1	1	1	1

Refrigerant

Type		R1234ze						
Charge Circuit 1	(kg)	41	40	40	42	55	55	60
Charge Circuit 2	(kg)	39	38	38	40	45	45	46

Dimensions & Weight

Length	(mm)	4520	4520	4520	4520	5645	5645	6770
Width	(mm)	2200	2200	2200	2200	2200	2200	2200
Height	(mm)	2526	2526	2526	2526	2526	2526	2526
Operating weight	(kg)	3410	3445	3445	4220	4365	3310	4470

Eurovent performances (1)		210	230	265	285	305	340
Net cooling capacity (1) (2)	(kW)	729	809	893	999	1083	1193
Net EER (1) (2)		3.20	3.07	3.15	3.15	3.06	3.11
Eurovent Energy class - Cooling		A	B	A	A	B	A
Net ESEER (2)		3.95	3.91	4.03	4.24	4.24	4.11
SEER (3)		4.54	4.22	4.49	4.46	4.53	4.62
Space cooling efficiency $\eta_{s,c}$ (3)	(%)	179	166	177	175	178	182
Sound power level	(dB(A))	94	94	94	95	95	95

Compressor

Circuit 1		2	2	2	2	2	2
Circuit 2		1	1	1	2	2	2

Refrigerant

Type		R1234ze					
Charge Circuit 1	(kg)	90	93	93	90	94	94
Charge Circuit 2	(kg)	40	44	49	88	91	96

Dimensions & Weight

Length	(mm)	8265	8265	9390	10135	10135	11260
Width	(mm)	2200	2200	2200	2200	2200	2200
Height	(mm)	2526	2526	2526	2526	2526	2526
Operating weight	(kg)	6715	6875	7230	8605	8765	9060

(1) Evaporator 12/7°C and 0.0 m²K/kW, and condenser at 30/35°C and 0.0 m²K/kW

(2) Net performances calculated as per EN 14511-2013.

(3) $\eta_{s,c}$ / SEER as defined in Directive 2009/125/EC of the European Parliament and of the Council with regard to Ecodesign requirements for Comfort Chillers with 2000 kW maximum capacity - COMMISSION REGULATION (EU) N° 2016/2281 of 20 December 2016

General specifications

SE



RTAF SE - Standard Efficiency - Standard and Low Noise

Eurovent performances (1)		100	110	145	185	210
Net cooling capacity (1) (2)	(kW)	360	391	506	608	734
Net EER (1) (2)		3.10	3.08	3.22	3.23	3.18
Eurovent Energy class - Cooling		B	B	A	A	A
Net ESEER (2)		3.56	3.55	3.82	3.81	3.97
SEER (3)		3.84	3.82	4.15	4.21	4.44
Space cooling efficiency $\eta_{s,c}$ (3)	(%)	150	150	163	165	174
Sound power level (standard noise)	(dB(A))	97	97	97	97	99
Sound power level (low noise)	(dB(A))	95	95	95	95	96

Compressor						
Circuit 1		1	1	1	1	2
Circuit 2		1	1	1	1	1

Refrigerant						
Type		R1234ze				
Charge Circuit 1	(kg)	40	40	55	60	90
Charge Circuit 2	(kg)	38	38	45	46	40

Dimensions & Weight						
Length	(mm)	4520	4520	5645	6770	8265
Width	(mm)	2200	2200	2200	2200	2200
Height	(mm)	2526	2526	2526	2526	2526
Operating weight (standard noise)	(kg)	3345	3345	4245	4350	6525

Eurovent performances (1)		230	265	285	305	340
Net cooling capacity (1) (2)	(kW)	816	897	1007	1092	1200
Net EER (1) (2)		3.06	3.14	3.13	3.06	3.11
Eurovent Energy class - Cooling		B	A	A	B	A
Net ESEER (2)		3.86	3.85	4.08	4.12	3.97
SEER (3)		4.20	4.44	4.40	4.44	4.41
Space cooling efficiency $\eta_{s,c}$ (3)	(%)	165	174	173	174	174
Sound power level (standard noise)	(dB(A))	99	99	100	100	100
Sound power level (low noise)	(dB(A))	97	97	98	98	98

Compressor						
Circuit 1		2	2	2	2	2
Circuit 2		1	1	2	2	2

Refrigerant						
Type		R1234ze				
Charge Circuit 1	(kg)	93	93	90	94	94
Charge Circuit 2	(kg)	44	49	88	91	96

Dimensions & Weight						
Length	(mm)	8265	9390	10135	10135	11260
Width	(mm)	2200	2200	2200	2200	2200
Height	(mm)	2526	2526	2526	2526	2526
Operating weight (standard noise)	(kg)	6675	7030	8365	8525	8820

(1) Evaporator 12/7°C and 0.0 m²K/kW, and condenser at 30/35°C and 0.0 m²K/kW

(2) Net performances calculated as per EN 14511-2013.

(3) $\eta_{s,c}$ / SEER as defined in Directive 2009/125/EC of the European Parliament and of the Council with regard to Ecodesign requirements for Comfort Chillers with 2000 kW maximum capacity - COMMISSION REGULATION (EU) N° 2016/2281 of 20 December 2016

RTAF-G

Process Units

With the introduction of a specific innovative design, optimized for negative temperature cooling, Trane Sinesis provides a highly efficient and sustainable (<1GWP) solution without any compromise on safety or reliability.

- Standard product designed for operation with brine
- Safe and efficient
- Environmentally responsible
- Cost effective choice

Operating limits

RTAF G Process		
Condenser Ambient Temperature		
Standard (min/max)	(°C)	-10 / +46
With Low Ambient option (min/max)	(°C)	-20 / +46
Evaporator Leaving Brine Temperature		
RTAF G Process range	(°C)	-12 / +4.4
Power supply	(V/Ph/Hz)	400/3/50
Refrigerant		R1234ze

Sintesis Prime RTAF-G Process Units are suited to critical environments like



Food and beverage industry



Cold Room



Industrial

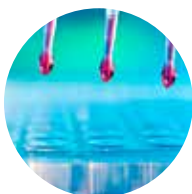

Pharmaceutical industry



Ice Rink



Milk Factory

RTAF-G

Process Units

A choice of 3 unit sizes with 2, 3 or 4 compressors running with 2 Adaptive Frequency™ Drives.

Unit Size HSE	Number of Compressors	Unit Length	Cooling Capacity	SEPR MT
		Meters	at -8 / -4 / 35 with 30% EG	
101	2	5.7	411 kW	3.42
141	3	8.3	599 kW	3.25
191	4	10.1	755 kW	3.27

An affordable choice of sound versions



- Choose from three levels of sound attenuation depending on the sensitivity of the application.
- Achieved without any loss of operating efficiency and even improving performances with the Extra Low Noise-EC version

Standard Noise: SN - 102 & 103 dB(A) sound Power

Low Noise: LN - 99 & 101 dB(A) sound Power

- Compressor enclosure
- Additional insulation on the refrigerant circuit

Extra Low Noise: XLN EC - 97 & 98 dB(A) sound Power



- Compressor enclosure
- Refrigerant line insulation
- EC Fans with top diffusers



RTAF-G

Process Units



Heat Recovery Option

Heat recovery is reusing the energy which is produced as a natural by-product of the cooling cycle. Trane Sintesis chillers with Partial or Total Heat Recovery option combine the energy savings from heat recovery operation with the cost savings from installation and maintenance. Units with the Heat Recovery option operate as a standard chiller as long as heat is not required or can simultaneously produce chilled and hot water for use in applications like:

- Heating or preheating of boiler systems or domestic cater
- Air conditioning
- Ventilation air pre-heating
- Industrial processes
- Defrosting system.

Specific for **negative temperature process applications**, Trane offers three levels of heat recovery, answering the very specific requirements of industrial users, such as fast defrost cycles.

- up to 25% of the cooling capacity with Partial Heat Recovery (PHR) option.
- up to 130% of the cooling capacity with Total Heat Recovery (THR) option.
- up to 50% of the cooling capacity with Partial Heat Recovery Plus.

Hydraulic Module

- Dual Pumps
 - Standard or high head pressure
- Smart Flow Control (size 101 and 191)
 - Constant water flow (adjust the pump speed without cooling demand)
 - Constant delta T control with variable flow
 - Constant delta P control with variable flow
- Optional Variable primary Flow 

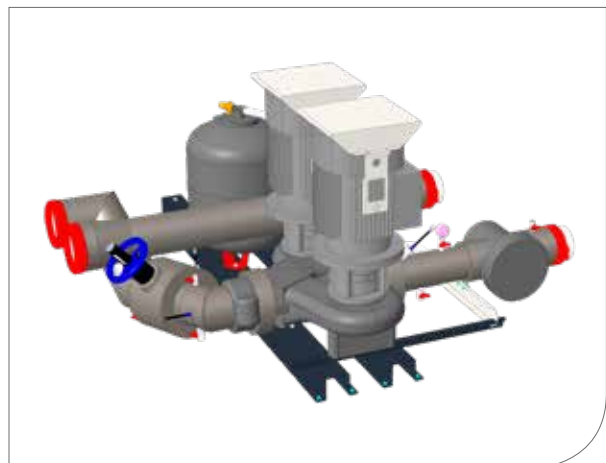

Family of air-cooled chillers and heat pumps

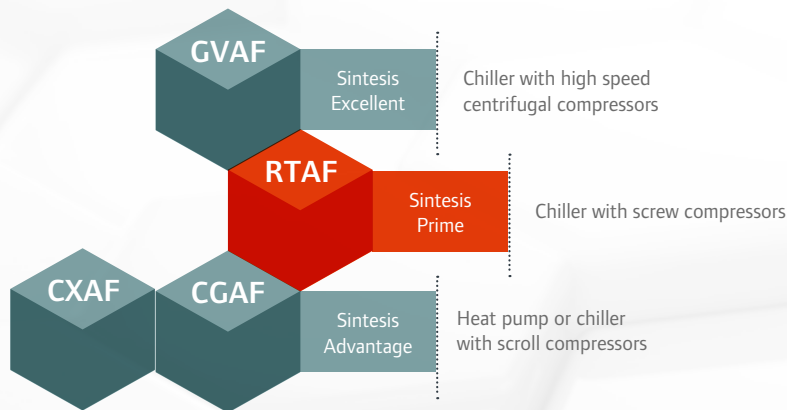

The Sintesis™ Prime model RTAF belongs to the Trane Sintesis™ air-cooled chiller and heat pump portfolio representing industry leading performance and flexibility. Always striving for a perfect fit, not only to your building and application requirements but also to your sustainability and budget targets.

The Trane Sintesis Prime range:

- Unit sizes providing cooling capacities from 300 - 2090 kW
- Five efficiency versions
- Three levels of sound attenuation
- 3 refrigerant alternatives
- Perfectly suited for comfort and process application with extended operating map:
 - Standard leaving water temperature range from +5°C up to +20°C
 - Low leaving water temperature range from +5°C down to -12°C with Glycol
 - Standard ambient option: from -10°C to 46°C
 - High ambient option: right up to 55°C
 - Low ambient option: right down to -18°C

Factory-mounted options:

- Hydraulic kit with dual pumps
- Smart flow control
- Partial heat recovery
- Total heat recovery
- Free-cooling
- For a complete and detailed list of all options and accessories, please refer to the product catalog or contact your local Trane office.



Trane® is a brand of Ingersoll Rand®. Ingersoll Rand (NYSE:IR) advances the quality of life by creating comfortable, sustainable and efficient environments. Our people and our family of brands—including Ingersoll Rand®, Trane®, Thermo King® and Club Car® — work together to enhance the quality and comfort of air in homes and buildings; transport and protect food and perishables; and increase industrial productivity and efficiency. We are a global business committed to a world of sustainable progress and enduring results.

